

# **Aerated Static Pile Composting**

## **Applications and Advancements**



**PART 1**

**INTRODUCTION AND OVERVIEW**

**PETER MOON - O<sub>2</sub>COMPOST**

# Objective: To Convert Raw Feedstocks



# Into High Quality Soil Amendments



# Using the Aerated Static Pile Method



Sonoma Valley Stables, Petaluma, CA

# Isometric View - Aerated Static Pile

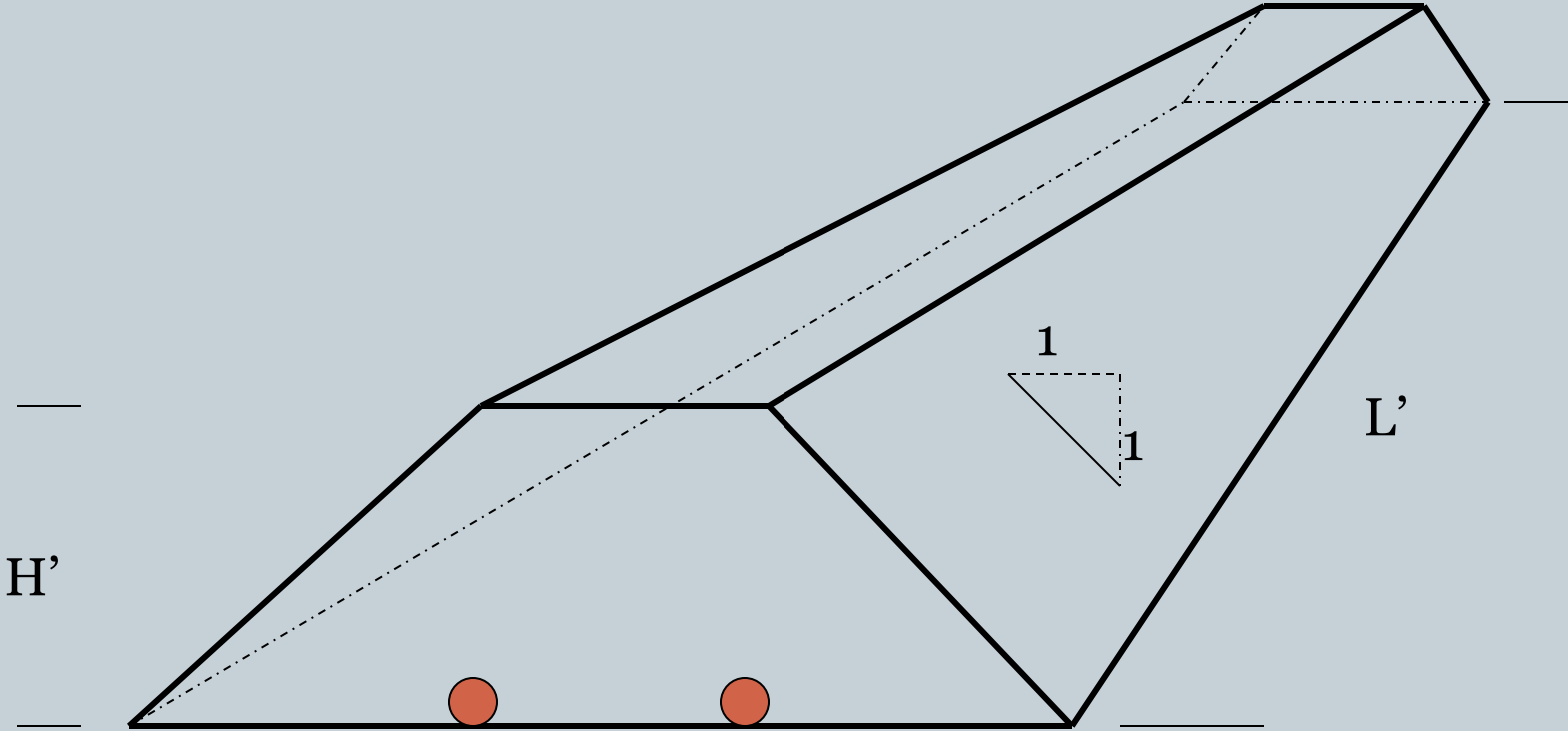

Rule of Thumb  
Max Pile Length 75 – 80-feet

# Section View of an ASP

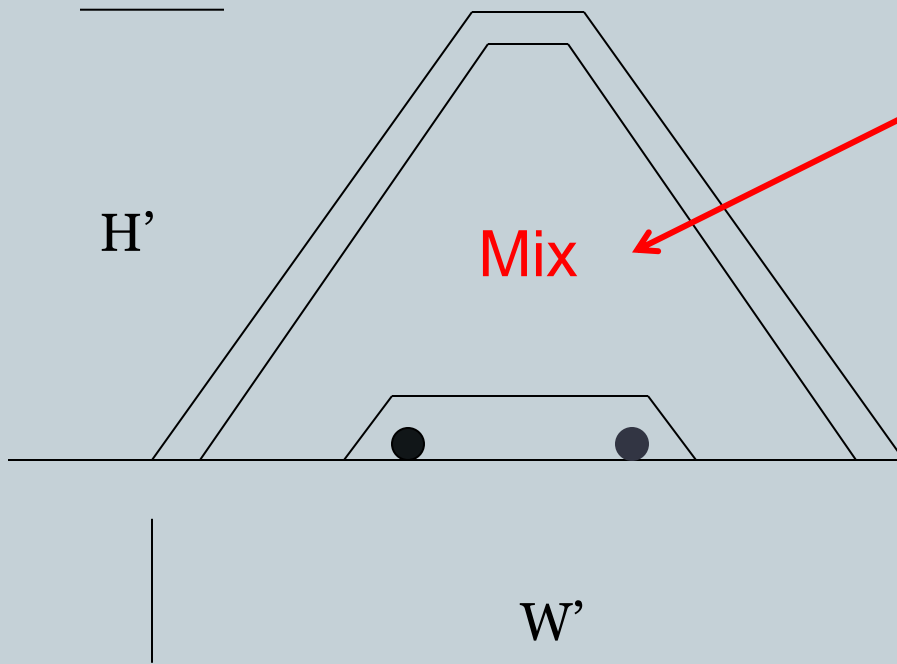

Pipes on Grade

Aeration Plenum Layer

Initial Mix of Materials

- C:N Ratio
- Bulk Density
- Moisture Content

Rule of Thumb:  
Max Pile Length 75 – 80-feet

# Biofilter Cover Layer



Unscreened Compost Cover (1-foot)

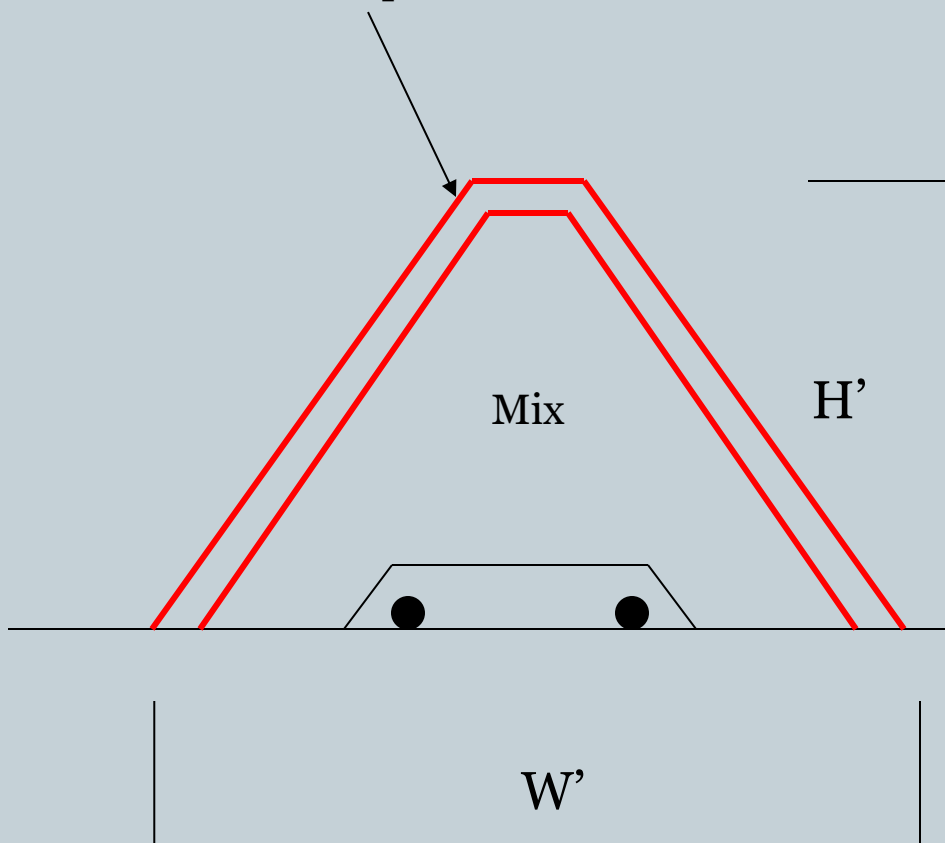

- Insulating Layer (PFRP)
- Biofiltration Layer
- Nutrient Retention
- Vector Barrier
- Moisture Retention
- Improve Aesthetics

Rule of Thumb:  
Max Pile Length 75 – 80-feet

# Partially Constructed ASP



ASP Hands-on Workshop



# Free-Standing Aerated Static Pile



Detweiler Homestead Farm, PA

# O<sub>2</sub>Compost Micro-Bin System



Plywood & 2 x 6 Tongue & Groove Bins

# 3-Bin Compost Structure



Follow Your Bliss Farm – Columbus, NC

# 3-Bin Compost Structure



Nickerson Farm – Sterling, MA

# Aerated Block Bay System



Thacher School – Ojai, CA

# Extended Aerated Static Pile



Two Particular Acres – Royersford, PA

# Extended ASP Composting



Upper Valley Disposal Service, Rutherford, CA

# ASP Composting is Easy!



- **WHEN YOU HAVE A SUITABLE MIX OF FEEDSTOCKS; AND**
- **MAINTAIN AEROBIC CONDITIONS THROUGHOUT THE PILE**
  
- **THE HEAT GENERATED IN THE COMPOSTING PROCESS:**
  - Destroys Pathogens;
  - Parasites;
  - Weed Seeds ;
  - Fly Larvae; and
  - Dissuades Vectors (rodents, birds and larger wildlife)



# What Can Be Composted?



- **GREEN WASTE (GRASS CLIPPINGS, PRUNINGS & LEAVES)**
- **FOOD WASTE (SOURCE SEPARATED ORGANICS - SSO)**
- **LIVESTOCK MANURE**
- **LIVESTOCK MORTALITIES**
- **INDUSTRIAL WASTE (OFFAL, COFFEE, MARIJUANA)**
- **BIOSOLIDS AND SEPTAGE**
- **HUMAN REMAINS (RETURN HOME, AUBURN, WA)**

# Composting Human Remains



## Return Home in Auburn, Washington

Watch This Video to Learn More

<https://returnhome.com/press-kit/>

# O2Compost Services



Compost System Design

Compost Facility Design

**Operator Training Programs**

Pilot Projects

# O2Compost Services



## Operator Training Programs include:

- Compost System Design Drawings
- Aeration Equipment Package
- Training Manual
- Unlimited Technical Support

# To Learn More about O2Compost



360.568.8085

**O<sub>2</sub>Compost**  
Compost Systems & Training

[HOME](#) [NEWSLETTERS](#) [REQUEST PROPOSAL](#) [CART](#)

[WHY O2COMPOST?](#) [COMPOST SYSTEMS](#) [SERVICES](#) [PROJECTS](#) [COMPOST 101](#) [PURCHASE](#) [BLOG](#) [CONTACT](#)



**FROM  
DESIGN TO  
DELIVERY**

We Guarantee Your Success

[GET YOURS TODAY](#)

# To Learn More about O2Compost



360.568.8085

**O<sub>2</sub>Compost**  
Compost Systems & Training

HOME NEWSLETTERS REQUEST PROPOSAL CART

WHY O2COMPOST? COMPOST SYSTEMS SERVICES PROJECTS COMPOST 101 PURCHASE BLOG **CONTACT**



# To Learn More about O2Compost



360.568.8085



HOME NEWSLETTERS REQUEST PROPOSAL CART

WHY O2COMPOST? COMPOST SYSTEMS SERVICES PROJECTS COMPOST 101 PURCHASE BLOG **CONTACT**



**FROM  
DESIGN TO  
DELIVERY**

We Guarantee Your Success

GET YOURS TODAY

# To Learn More about O2Compost



**Peter Moon, P.E.**

[peter@o2compost.com](mailto:peter@o2compost.com)

[www.o2compost.com](http://www.o2compost.com)